



Model: 28-201 Item #: _____ Date: _____

Project: _____ Qty: _____ Approved By: _____

Front Caster Positioning Chock

Caster Accessories



28-201

Krowne's Front Caster Positioning Chocks are designed to work with our 28-200 Rear Caster Chocks to meet local codes that require caster chocks on the front and rear wheels. Caster Chocks are designed to create a home position for all movable kitchen equipment to ensure they are always returned back to the proper location, in relation to fire suppression and ventilation systems after the removal for cleaning and maintenance purposes.

Standard Features

- Can be used with all caster-mounted equipment
- Heavy duty stainless steel construction
- Easy installation
- Satisfies requirements of NFPA Codes 17A (5.6.4) and 96 (12.1.2.3)
- Includes (2) Stainless Steel Caster Positioning Chocks, (8) Hex Screws, (8) Drop In Anchors

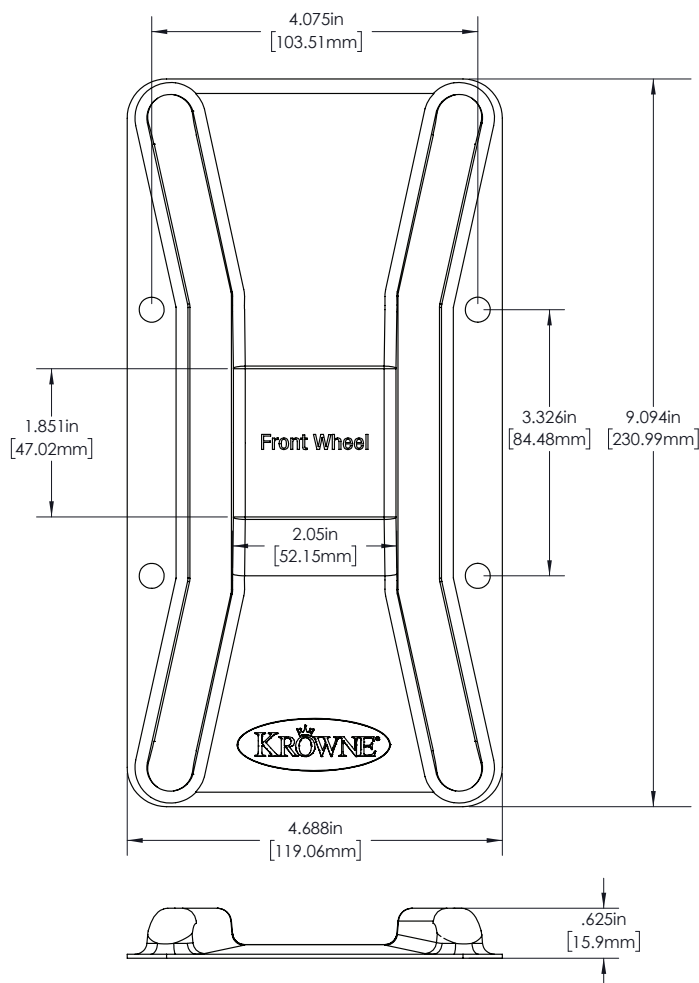

Note that the chock is positioned so the kitchen appliance is stationed under the hood.

