

Front Mount Dipper Well with Dipper Well Faucet

Royal Series Plumbing



Model	Description
16-153L	Front Mount Dipper Well with Dipper Well Faucet

Product Compliance (Faucet)

- NSF-61 & NSF/ANSI 372
- NSF/ANSI/CAN 61: Q < 1
- ASME A112.18.1-2012/CSA B125.1-12
- Massachusetts Approved
- CEC Approved



Standard Features

- 304 stainless steel construction, satin finish
- Mounts with (3) screws (not included)
- Includes 16-151L dipper well faucet with shut-off valve
- Single welded, removable divider/overflow that splits bowl
- Front mount
- Mounting bracket for faucet
- G1 drain thread
- Weight: 4 lbs.

Specifications (Faucet)

Model	16-151L
Water Inlet	1/2" NPS
Temp. Range	40°F - 140°F
Pressure	20-120 PSI
Rough In	7/8" single hole
Flow Rate	1.33 GPM (60 PSI)
Material	Solid brass
Finish	Polished chrome



Dipper Well Faucet Replacement Valve (New Style)
Fits Dipper Well Faucets 16-151L and 16-155L
Model: **16-158**

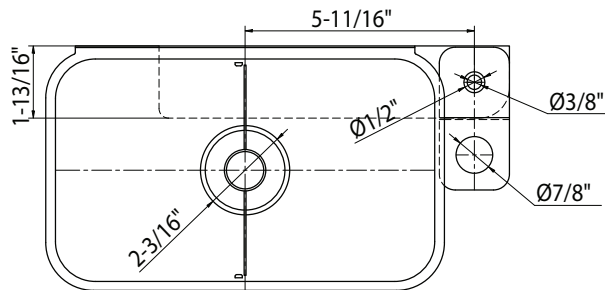
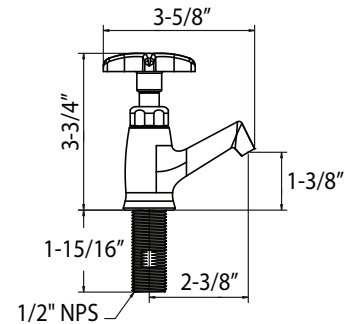
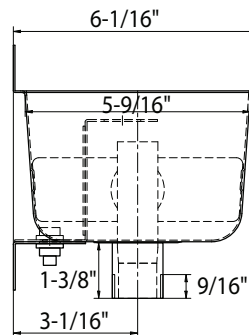
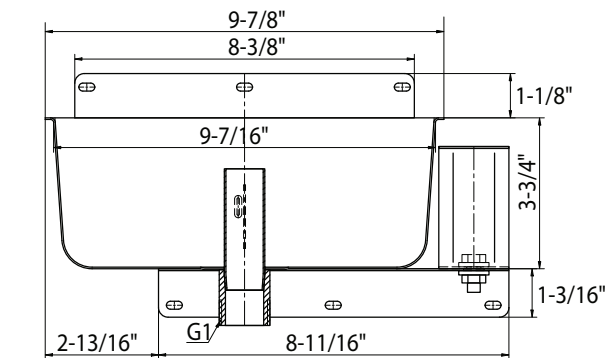

WARNING:

Plumbing connections should be made by qualified personnel who will observe all applicable plumbing, sanitary and safety codes.

California Prop 65 Warning:

This product can expose you to chemicals including lead and lead compounds, which are known to the State of California to cause cancer and birth defects or other reproductive harm. For more information go to www.P65Warnings.ca.gov.