



Model: \_\_\_\_\_ Item #: \_\_\_\_\_ Date: \_\_\_\_\_  
 Project: \_\_\_\_\_ Qty: \_\_\_\_\_ Approved By: \_\_\_\_\_

## ADA Compliant Hand Sinks

## HAND SINKS

### HS-50

4" Center Deck Mount with  
Wrist Blades & Soap Dispenser



### HS-51

Single Hole Deck Mount  
Hands Free Electronic Sensor Faucet



### HS-53

8" Center Deck Mount with Wrist Blades



### SPECIFICATIONS

<b>Overall Size</b>	20"W x 24"L x 16"H
<b>Bowl Size</b>	14"W x 16"L x 5" Deep
<b>Wall Bracket</b>	Keyhole with offset design for added strength
<b>Drain</b>	1-1/2" stainless steel
<b>Faucet</b>	4" center wall mount faucet included on most models
<b>Drain</b>	1-1/2" stainless steel
<b>Fabrication</b>	Seamless one piece deep drawn sink bowl Type 304 series stainless steel All tig welded Welded areas blend to match adjacent surfaces
<b>Plumbing</b>	1/2" IPS male hot and cold water 1-1/2" IPS drain outlet

### PRODUCT SPECIFIC FEATURES

<b>HS-50</b>	<ul style="list-style-type: none"> <li>4" center deck mount faucet</li> <li>6" double bend spout</li> <li>Wrist blade handles</li> <li>Faucet contains 1/4 turn ceramic valves</li> <li>Deck mount liquid soap dispenser</li> <li>24 lbs.</li> </ul>
<b>HS-51</b>	<ul style="list-style-type: none"> <li>Single hole deck mount hands free electronic sensor faucet</li> <li>6" gooseneck spout</li> <li>Deck mount liquid soap dispenser</li> <li>Electronic faucet includes 3 year warranty</li> <li>24 lbs.</li> </ul>
<b>HS-53</b>	<ul style="list-style-type: none"> <li>8" center deck mount faucet</li> <li>6" double bend spout</li> <li>Wrist blade handles</li> <li>Faucet contains 1/4 turn ceramic valves</li> <li>26 lbs.</li> </ul>

### PRODUCT COMPLIANCE

- NSF-2
- CSA Listed
- ADA Compliant



**Warning:** This product can expose you to chemicals including lead and lead compounds, which are known to the State of California to cause cancer and birth defects or other reproductive harm. For more information go to [www.P65Warnings.ca.gov](http://www.P65Warnings.ca.gov).



Model: \_\_\_\_\_ Item #: \_\_\_\_\_ Date: \_\_\_\_\_

Project: \_\_\_\_\_ Qty: \_\_\_\_\_ Approved By: \_\_\_\_\_

# ADA Compliant Hand Sinks

# HAND SINKS

## HS-50

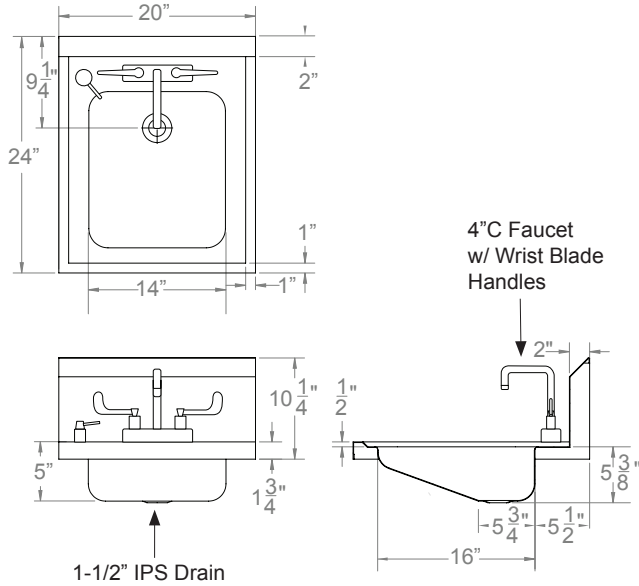

## HS-51

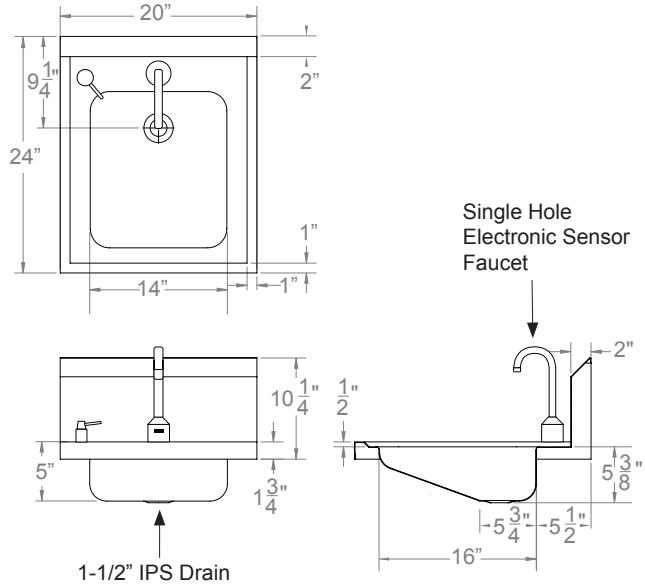

## HS-53

