

8" Center Wall Mount Pre-Rinse

DIAMOND SERIES



Standard Features

- 1/4 turn stainless steel high performance ceramic cartridge valves with built-in check valves
- Heavy Duty Flanges with eccentric fittings and innovative flange seal
- Dual Spray Technology, 1.15 GPM Knife & Cyclone Options
- Lever Handles
- Adjustable Wall Bracket & mounting kit included
- E-Z install flexible water line kit included
- Lifetime Warranty

Specifications

Water Inlet	1/2" NPS Male; Kit Installed
Temp. Range	40°F - 180°F
Pressure	20-120 PSI
Spray Head Flow Rate	1.15 GPM
Finish	Ultra-Polish Satin
Body Material	Solid Brass
Dimensions	35" High 15" Overhang
Weight	16 lbs.

Model	Description
DX-108	8" Center Wall Mount Pre-Rinse

Product Compliance

- NSF-61 & NSF/ANSI 372
- NSF/ANSI/CAN 61: Q < 1
- ASME A112.18.1-2012/CSA B125.1-12 & NSF/ANSI 372
- Meets ANSI A117.1 (ADA)
- Massachusetts Listed

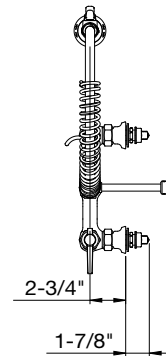
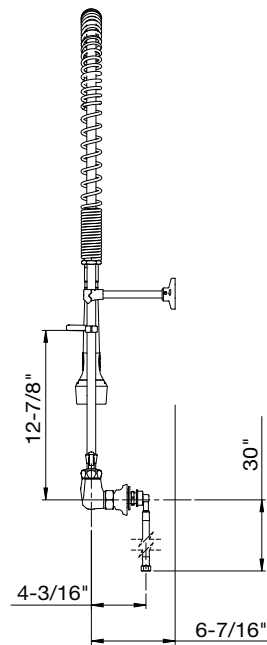
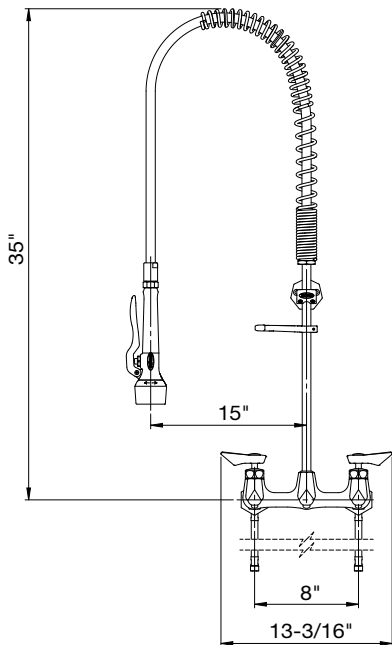

Warning:

Plumbing connections should be made by qualified personnel who will observe all applicable plumbing, sanitary and safety codes

California Prop 65 Warning:

This product can expose you to chemicals including lead and lead compounds, which are known to the State of California to cause cancer and birth defects or other reproductive harm. For more information go to www.P65Warnings.ca.gov.

8" Center Wall Mount Pre-Rinse

DIAMOND SERIES

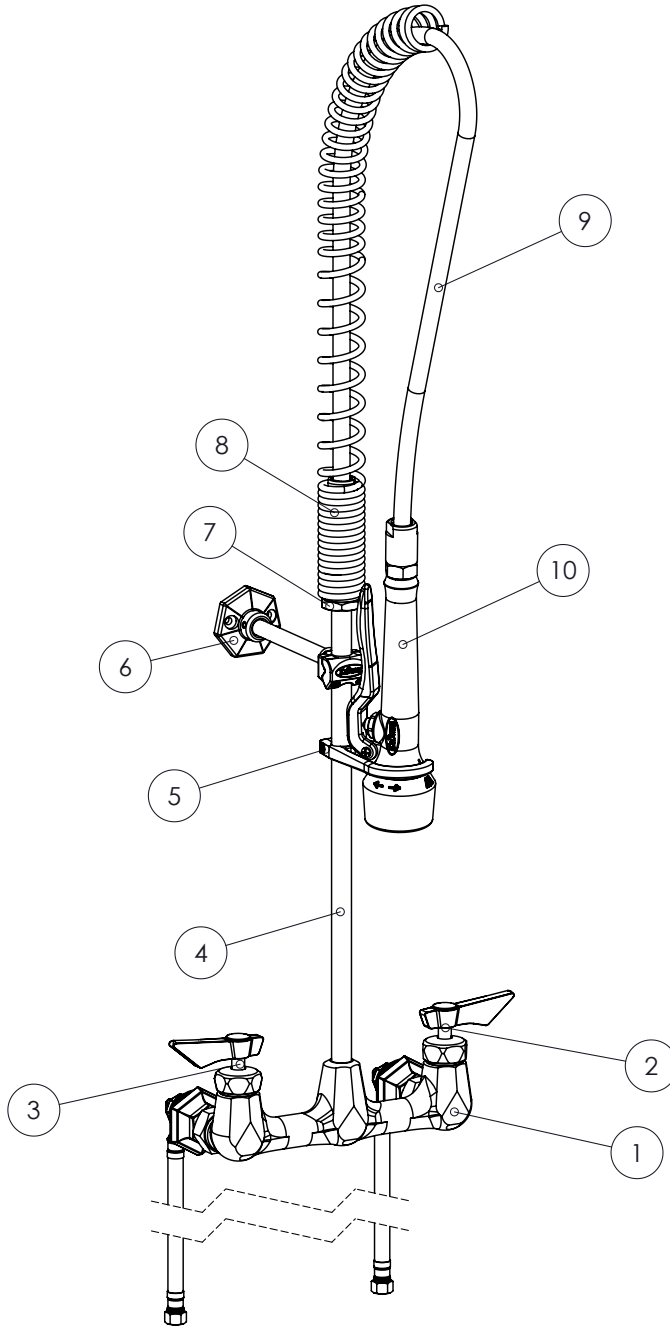

Replacement Parts

No.	Model	Desc.
1	DX-208	8" Center Wall Mount Pre-Rinse Base
1	DX-100	(2) Coupling Flanges
2	DX-708	Cold 1/4 Turn Ceramic Cartridge Valve
3	DX-709	Hot 1/4 Turn Ceramic Cartridge Valve
4	DX-160	18" Riser Pipe
4	DX-160-24	24" Riser Pipe
5	DX-165	Hook/Screw Assembly
6	DX-137	Wall Bracket
7	DX-161	Spring Retainer
8	DX-162	24" Spring
9	DX-133	44" Pre-Rinse Hose
10	DX-129	Spray Head (1.15 GPM)

Spray Head Repair Parts

Model	Description
DX-166	Repair Kit for Spray Head (Shower Pattern)
DX-171	Spray Head Handle
DX-179	Repair Kit for Spray Head (Knife Pattern)
DX-322	Button Valve