



Model: **DX-109** Item #: _____ Date: _____
 Project: _____ Qty: _____ Approved By: _____

8" Center Wall Mount Pre-Rinse Includes Add-On Faucet w/ 12" Spout

Diamond Series Plumbing



STANDARD FEATURES

- Pre-assembled to cut installation time
- Includes wall bracket with mounting hardware
- 1/4 turn stainless steel ceramic cartridge valves
- 44" stainless steel hose with grip
- Interchangeable with most brands
- Built-in check valves
- Built for high volume
- Full replacement parts available
- Lifetime Warranty

SPECIFICATIONS

Water Inlet	1/2" NPT Female Inlets
Temp. Range	40°F - 180°F
Flow Rate	1.15 GPM
Material	Chrome plated brass
Weight	15 lbs.

PRODUCT COMPLIANCE

- ASME A112.18.1/CSA B125.1
- NSF-61
- NSF/ANSI 372
- Meets ANSI A117.1 (ADA)
- California Proposition 65

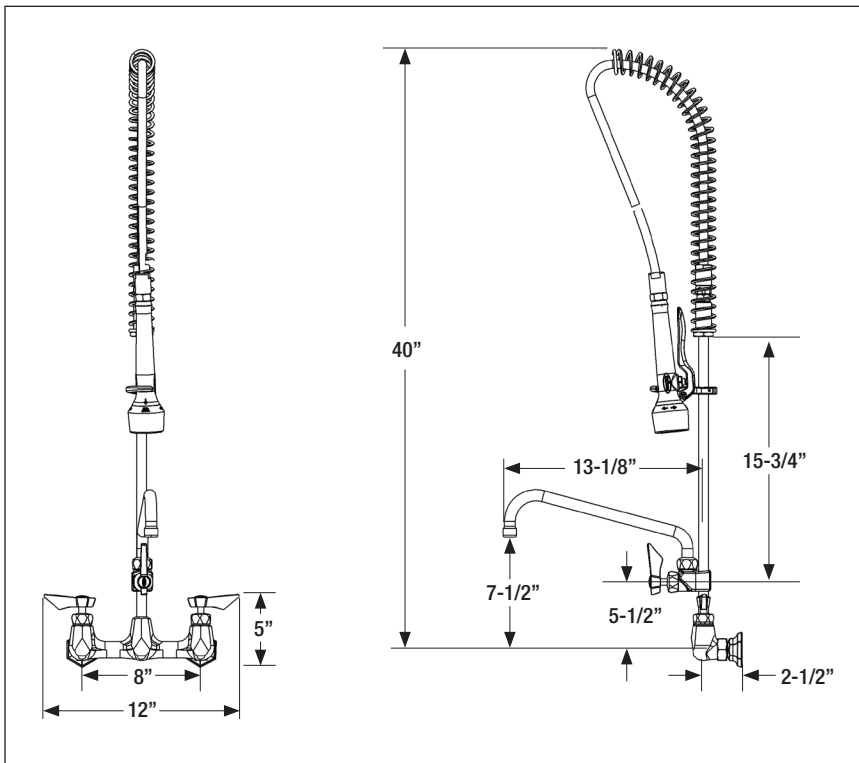

REPLACEMENT PARTS

DX-100	Wall Mount Supply Inlets
DX-129	Spray Valve (1.15 GPM)
DX-133	44" Pre-Rinse Hose
DX-137	Wall Bracket
DX-139	Add-On Faucet with 12" Spout
DX-148	Replacement Bumper for Spray Head
DX-160	18" Riser Pipe
DX-160-24	24" Riser Pipe
DX-161	Spring Retainer
DX-162	24" Spring
DX-165	Hook/Screw Assembly
DX-166	Repair Kit for Spray Head (1.15 Shower Pattern)
DX-171	Spray Head Handle
DX-179	Repair Kit for Spray Head (1.15 Knife Pattern)
DX-208	8" Center Wall Mount Pre-Rinse Base
DX-308	Cold 1/4 Turn Ceramic Cartridge Valve
DX-309	Hot 1/4 Turn Ceramic Cartridge Valve

WARNING: Plumbing connections should be made by qualified personnel who will observe all applicable plumbing, sanitary and safety codes.