

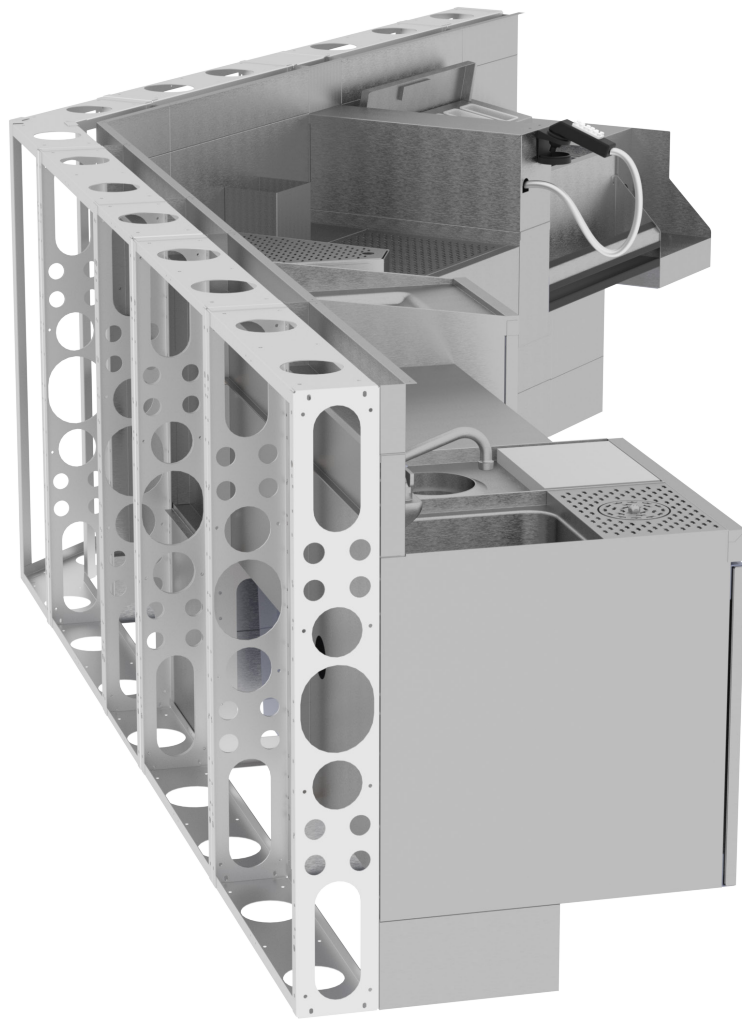

Modular Bar Die

Installation Manual





Modular Bar Die

**Built-in chaseways for soda, beer, electrical & plumbing lines.
Elimination of legs create a sealed-to-floor finish.**

Krowne Modular Bar Die (KMB) is designed to significantly reduce installation time while improving overall aesthetics and cleanability. The most time consuming portion of an underbar installation consists of the field layout/assembly of bar sections, and the construction of the bar frame in which the sections are attached.

Our modular bar units ship completely assembled in sections up to 8 ft. to drastically cut down time and labor while ensuring a sleek finish. Replacing legs with stainless steel panels that mount flush to the floor prevent debris from building up under the equipment.



Available in any shape or size



Built for indoor and exposed applications.

Advantages to Modular Bar Die

- Bar die structure fabricated out of 16 ga. stainless steel (stainless steel finish on bartender side to hide drains & plumbing)
- Bartender-side: 20 gauge 300 series stainless steel
- Units pre-assembled at factory and shipped in sections up to 8' for easy installation (cuts installation costs)
- Supports 1,000 pounds per foot of downward force
- Built-in chaseways for plumbing, electric, soda, beer, and other utility lines
- Die wall sealed-to-floor design prevents seepage
- Bar top and front panels can be easily installed to structure
- No legs required. Units attached to bar die structure for quick and easy cleaning.
- Built-in electrical outlets installed per customer's request (quantity and location to be verified)
- Bartender-side panels removable for drain access
- End panels (by millwork) easily removed for access to soda, beer, electrical and plumbing lines for future service or repair
- We recommend customer-side panels are built by millworker to be removable
- Bar die can be upgraded to stainless steel

Modular Bar Die Specifications

Mechanical

- **Utility lines:** Dedicated chase locations for hot/cold water supply lines, beverage line conduits, and electrical conduit (behind the underbar equipment) this chase is accessible from the floor and runs the entire length of the bar.
- **Floor drains:** Locate floor drains directly below workboard equipment. The number of floor drains will vary depending on the bar layout and local codes.
- **Millwork:** Done by outside contractors

Utility

A 5-1/2" open zone is furnished behind the equipment to provide room for various lines (trunk lines, soda lines, plumbing, electrical, etc.) to travel vertically or horizontally within the bar structure. Connections can be made from the front of the bar with panels removed.

Electrical

All electrical requirements such as receptacle to blenders, washers, coolers, soda guns, light, etc. (by others).

Plumbing

All water service and waste connections can be made from the front of the bar (decorative front panel removed). Local codes dictate installation (by others).

General Specifications

- **Structure:** Configured to the exact size and shape of underbar equipment, freestanding cabinets and openings, as specified.
- **Chase:** Interior chase runs the entire length of the structure including corners.
- **Millwork:** Done by outside contractors

Tools Required

For proper installation, it is important to have the following tools on hand before starting the installation.

- Phillips head screw driver
- Level
- Tape measure
- Chalk line
- Power drill
- Shims for leveling
- 7/16 ratchet wrench
- 7/16 box wrench or adjustable wrench
- 1/4" x 7/16 hex head bolts and nuts (used for adjoining modular bar sections to each other. Krowne suggests that the hex heads that are included be sealed with sealant upon installation.)
- #8 Self starting galvanized screws (used for modular front panels & anchoring to floor).

Fasteners are supplied in a plastic bag with your bar die.

Make sure all screws are facing the same direction when adjoining modular sections for maintenance purposes.

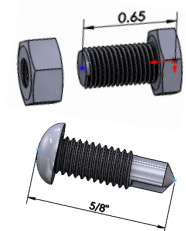

Modular Bar Die Chaseways

Chaseways allow for easy installation and access to beer, water, electrical, plumbing and other utility lines.

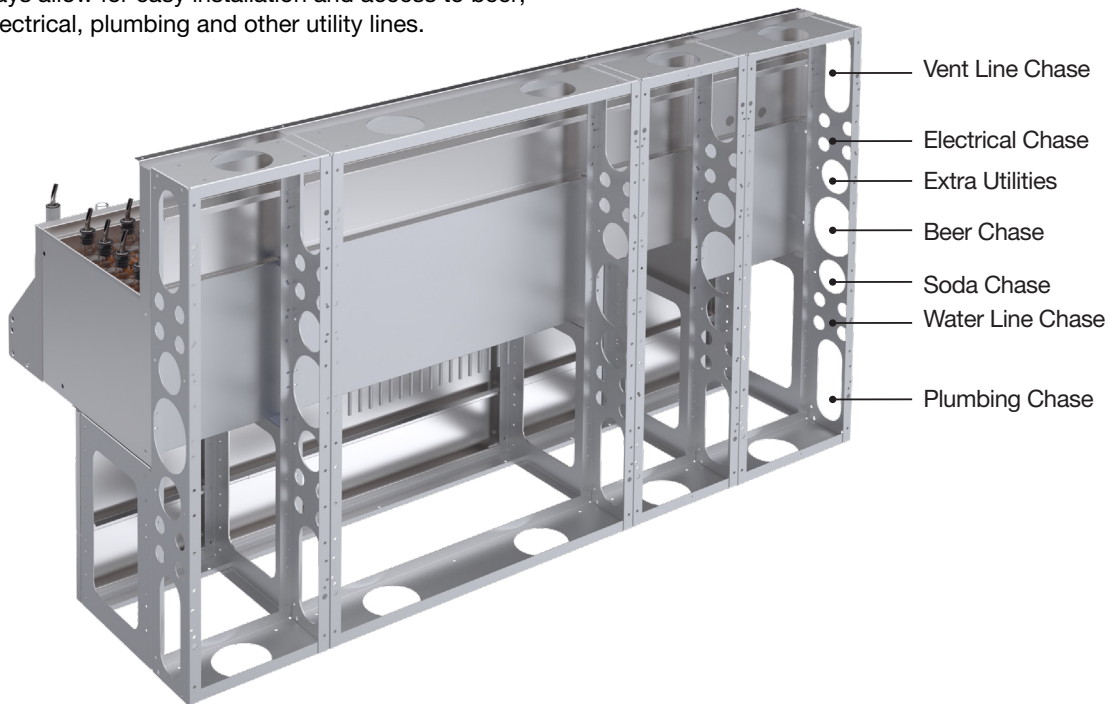

LED Light Specifications

Models	25 Watt Power Supply (KMB-PS-25) 60 Watt Power Supply (KMB-PS-60)
Features	No glare, down-angled beam. Rugged and waterproof. Brushed nickel oval bezel. Includes stainless steel pre-punched wall plate, (1) 2" x 4" electrical box
Colors	Cool Blue (KMB-LK-B)
Input Voltage	9-30V DC, 9-15V AC

Input Power	1.5 Watts Typ, 2.5 Watts Max
Lumens	17 lms typ @3000 °K
IP Rating	IP67
Wiring	6" Twisted 18 AWG

Wiring Example 12/24V DC No Dimming

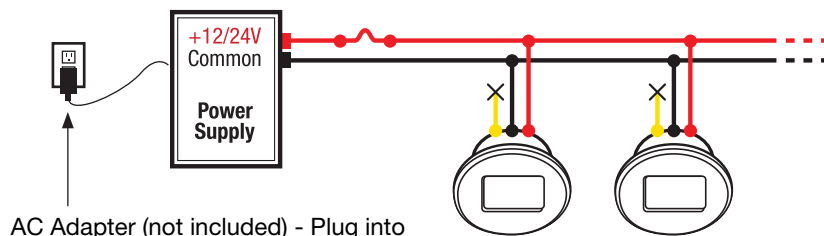

AC Adapter (not included) - Plug into building wall receptacle. Receptacle to be controlled by a wall switch. Receptacle and wall switch by electrical contractor.

Recommended spot for LED power supply and switch on diagram:

The master switch location is determined by customer preference but we recommend not placing it near a sink and it must meet local district code. Follow these same guidelines for the outlet location. The transformer should be installed in the back of the mod wall and it must be easily accessible by local district code. We recommend having it plug into an outlet.

Typical Bar Sections with Modular Bar Die

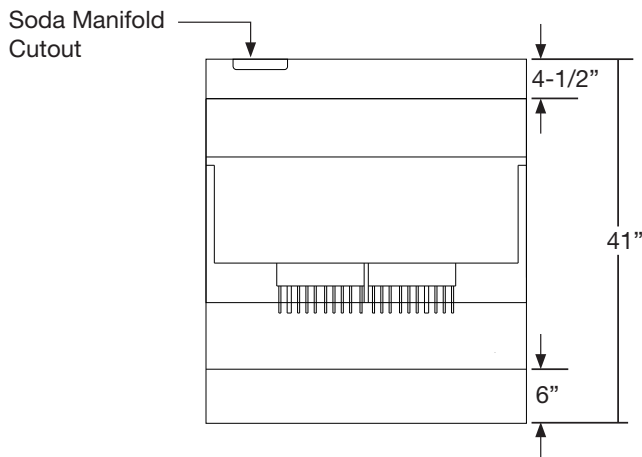
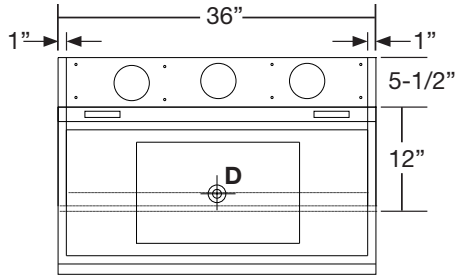

Ice Bin (Side View)

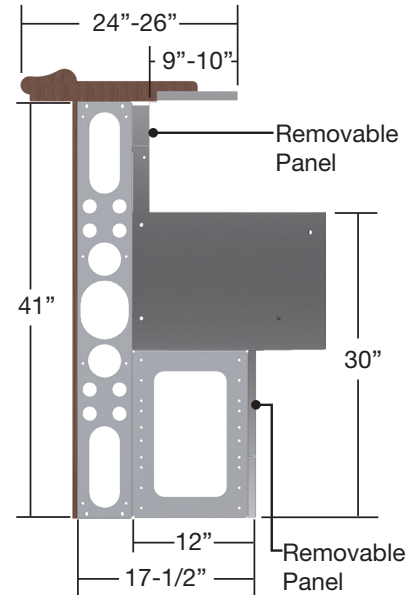

Cabinet (Side View)

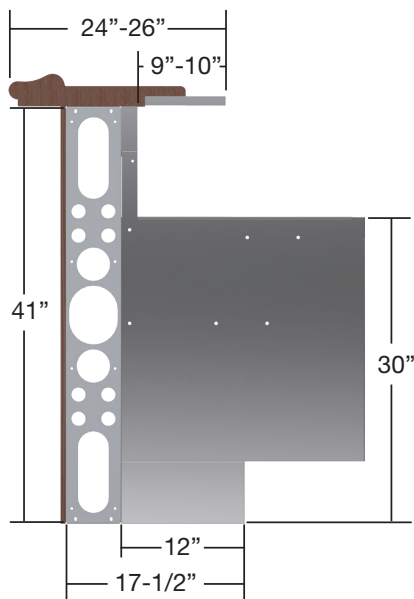

Bar Sink (Side View)

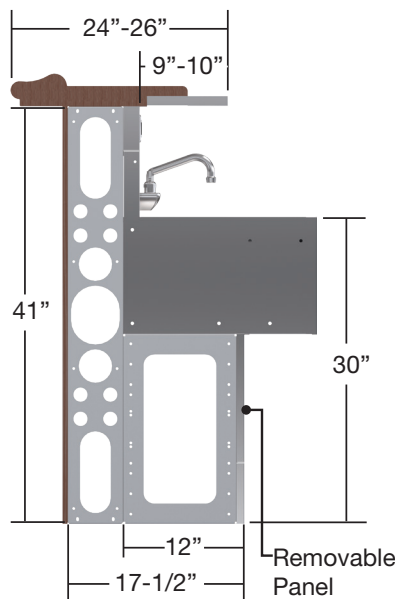

Modular Bar Die Chases

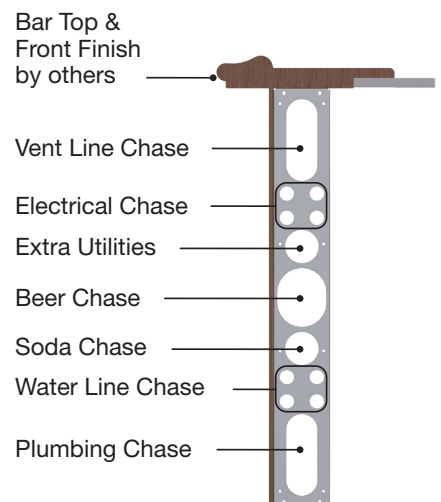

Typical Bar Assembly Detail with Modular Bar Die

Below is an example of a typical bar assembly using modular bar die.

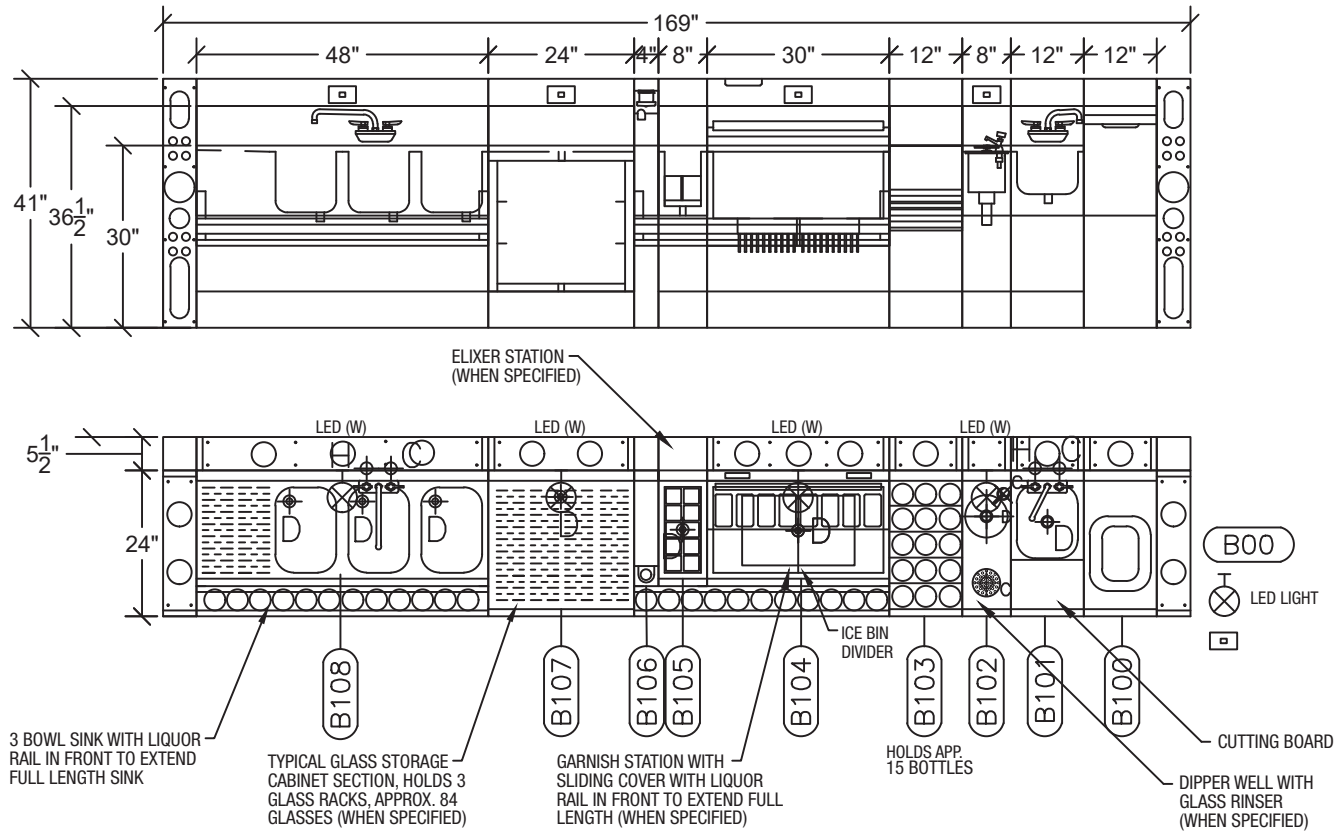

Typical Equipment Schedule

No.	Qty	Krowne Model	Description	Equipment Remarks
B00	23	KMB	Modular Bar Die System	
B100	1	KR24-T12	12" Dry Waste Trash Chute	
B101	1	KR24-MC12	12" Speed Unit with Dump Sink, Cutting Board	
B102	1	KR24-MD8	8" Speed Unit with Dipperwell, Speed Rinser	
B103	1	KR24-ML12	12" 5-Step Liquor Display	RS-42; KR-521
B104	1	KR19-30-10	30" Ice Bin with Cold Plate	
B105	1	KR19-ME8	8" Elixir Station	
B106	1	KR19-4SH-L	4" Soda Gun Holder	
B107	1	KR24-GSB1	24" Glass Storage Cabinet with 3 Adjustable Racks	
B108	1	KR19-43R	48" 3-Compartment Bar Sink	RS-48

LED Lights and Outlets

Model	Description
KMB-LK-B	Cool Blue LED Light (1.5 Watts Output)
KMB-PS-25	25 Watt Power Supply for up to 10 LED Lights
KMB-PS60	60 Watt Power Supply for up to 25 LED Lights

Options

ADA Certified

Providing an equal opportunity to people with disabilities is the fundamental principle of the American with Disabilities Act. Krowne embraces this and provides options to have wheel chair accessible modular bar die added as an option.

ADA Requirements for Foodservice Counters and Bars

Where food or drink is served at counters exceeding 34" (865 mm) in height for consumption by customers seated on stools or standing at the counter, a portion of the main counter, which is 60" (1525 mm) in length minimum, shall be provided in compliance with 34" maximum counter height and 19" clear depth, or service shall be available at accessible tables within the same area.

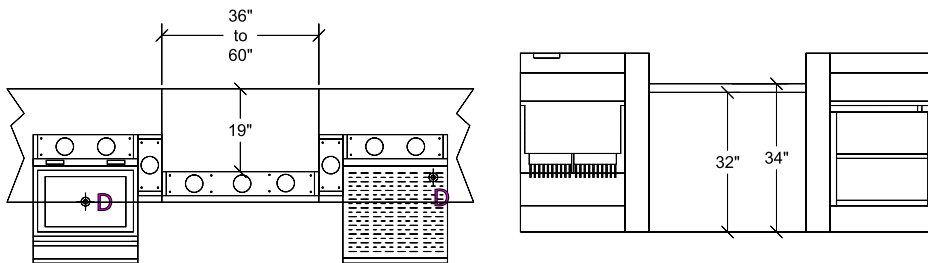

Confirm size with local codes. 36" to 60" depending on local code requirements

Built-In Outlets

Built-in electrical outlet boxes installed per customer's request (quantity and location to be specified).



LED Lights

Illuminate your bar with down acting LED lights. Color options include crisp white, warm white, blue, green, cyan, and red. Power supply may also be purchased with LED lights.



Mylar Template

Mylar template can be ordered prior to equipment going into production and is used to see precise footprint of modular bar equipment. Template is priced out per linear foot and is sent in sections labeled A thru Z for ease of layout. Template allows for accurate marking of floor drain locations and beer/vent lines along with the added benefit of spatially visualizing your future bar. Mylar sections are sent in up to 200" in length.

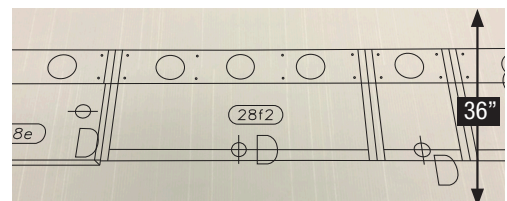

Installation

1. Uncrating

Remove all shipping material from units. Inspect the units for any damage that could have occurred in transport. Report any damage immediately to Krowne by calling 800-631-0442.

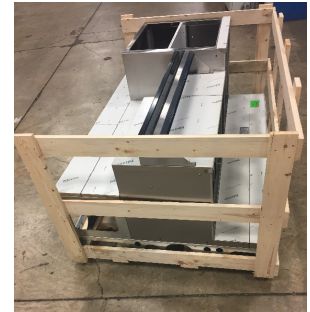

2. Placing

Set units in place according to the CAD drawings provided with equipment in the box marked "Parts and Instructions." Die wall should be placed over existing soda/beer line conduits, plumbing and electrical stub ups.

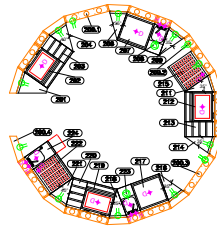

3. Adjoining

After units are set in desired location, loosely attach sections using the hex bolts and nuts supplied with equipment (7/16 ratchet and box wrench will be needed for this step). Krowne suggests that the hex heads that are included be sealed with sealant upon installation.



4. Leveling

After all sections have been bolted together and placed in the desired location, units should be leveled using shims. (Shims and standard level required for this step).



Installation

5. Anchoring

Once all units are fully leveled, tighten all bolts and nuts. Next, attach the modular bar die to the ground through pre-cut 1/4" holes on the bottom of the die wall. Your contractor will pick the best installation method for your application.



6. Utility Lines

All plumbing, electric, beer, soda & vent lines should be installed by a licensed professional to maintain factory warranty. Refer to diagram for proper placement of all lines.

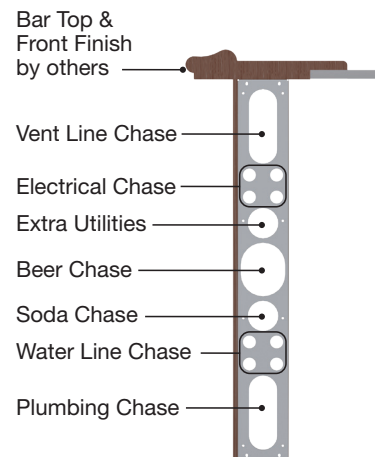
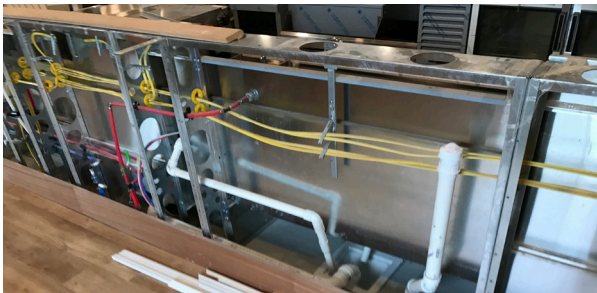

7. Freestanding Units

Free standing equipment such as bottle coolers, mug frosters, back bar, and glass washers can be placed into their designated sections according to the floor plan. Bottle coolers and mug frosters should be installed with a 2" gap on the left side for proper ventilation. Krowne includes this 2" gap in layout drawings.



8. Sealing

We recommend using NSF approved silicone to seal all joints near the floor (SIL-BOND 45000 RTV Silicone Sealant – Aluminum). Tile can be abutted to the front floor panels and then sealed."

Installation

9. Front Panels (Everything shown in brown is supplied by millworker.)

Install bar counter and removable front millwork panels. It is very important to have the front panels removable to allow access from the customers side for plumbing, electrical and beverage lines. Front panels use interlocking panels and hidden screws meaning they make accessing the underside of the bar very easy and the screws cannot be seen by customers.

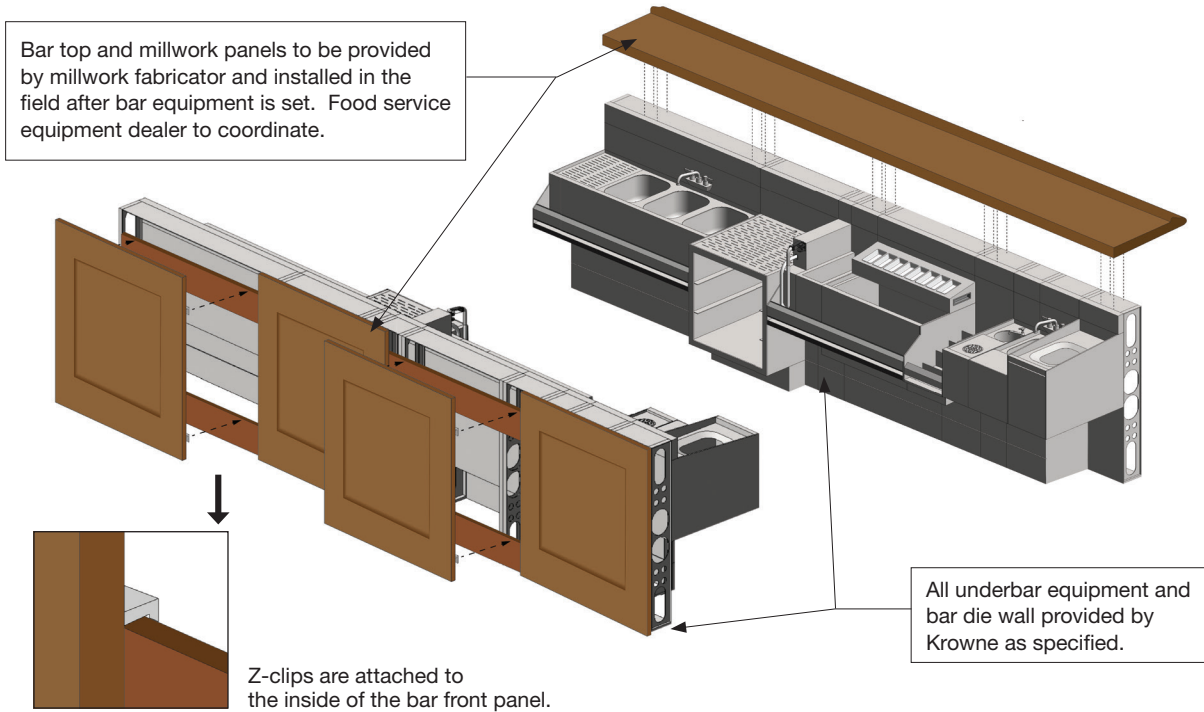

METHOD A

Metal Z-clips are attached to the inside of the bar front panel.

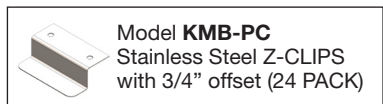

Panels should be milled to leave a space approximately the width of a z-clip leg. This allows for easy panel removal for maintenance.

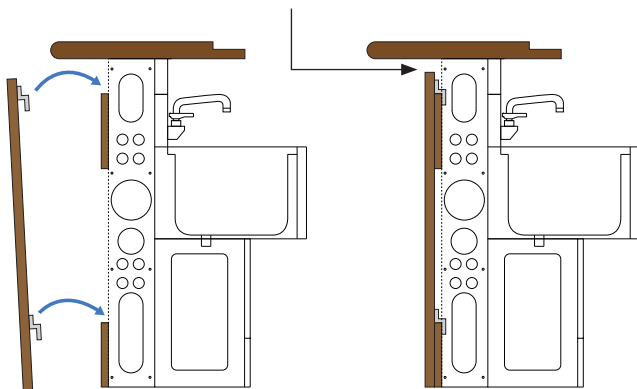

Wood should be 3/4" thick to fit Z-clips

METHOD B

Slide panel into channel created by two pieces of wood.

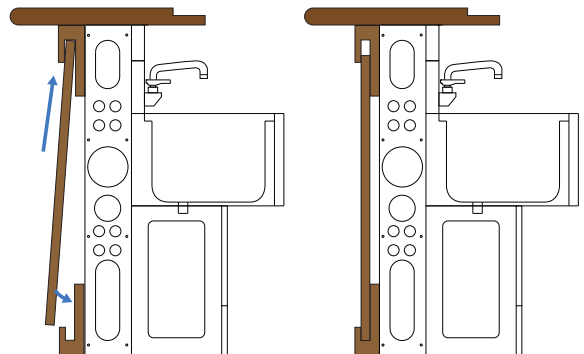



100 Haul Rd. Wayne, NJ 07470

P: (800) 631-0442

krowne.com