

KRÖWNE®

UC48L MoveWell Ultra-Low Profile Refrigerator Manual



UC48L CHARACTERISTIC SPECIALITIES

Climate Class	:D
Safety Class	:1
Working Temperature C	:28.4F / 46.4F
Thermostate Set Temperature	:30.2F
Environment Temperature	:109.4F
Environment Moisture Propertion	: 65%
Energy Consuption	:0,17 KW/H
Power	:0,26 KW
Voltage	:220V / 50 Hz

ACCESSORIES AND CONTROL SWITCHES

Digital Thermometer	: Digital Thermometer
Energy Lamp	: Ad / PCC1
Power Switch	: Ad / PCS1
Hinges Group	: Ad / PCS2
Base	:Stainless Steel Legs

TECHNICAL CHARACTERISTICS

Outside Dimensions	: 55 X 23.5 X 23.5 in
Inside Dimensions	: 32.5 X 18.2 X 15.4 in
Package Dimensions	: 59 X 27.5 X 29.5 in
Inside Volume	: 33 gal
Gross Weight	: 242.5 lbs
Net Weight	: 198.5 lbs
Insulation Material Thickness	: 2 in
Compressor	: EMT 6160 Z (1/4HP)
Condenser	: 1/4 HP hood condenser
Condenser Fan	: 10/38 W--0,45A--1300/1550 Rpm--230V
Evaporator	: NTV tip evap / NTV type evap
Evaporator Fan	: Coprel W5/2A--13/26W--230V-50/60Hz x 2 Adet
Dryer	: 30 gr 15002SGDR02 Double entry
Refrigerator Gas	: R134 A
Ref. Gas Quantity	: 380 grams
Certifications	: TS 2225 EN 60335-2-4'
Serial No	: Serialized per unit
Packing	: Wooden Pallet

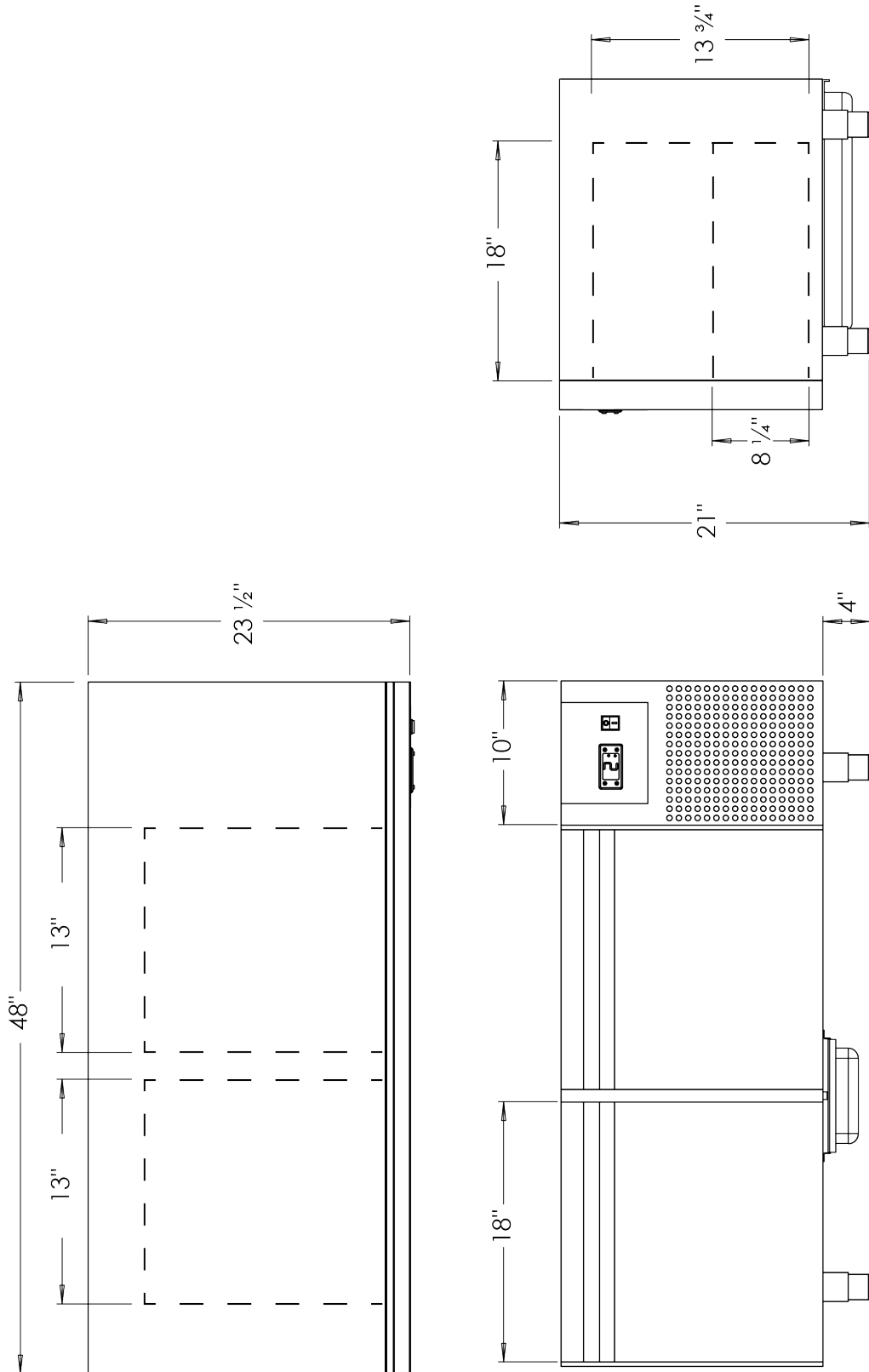

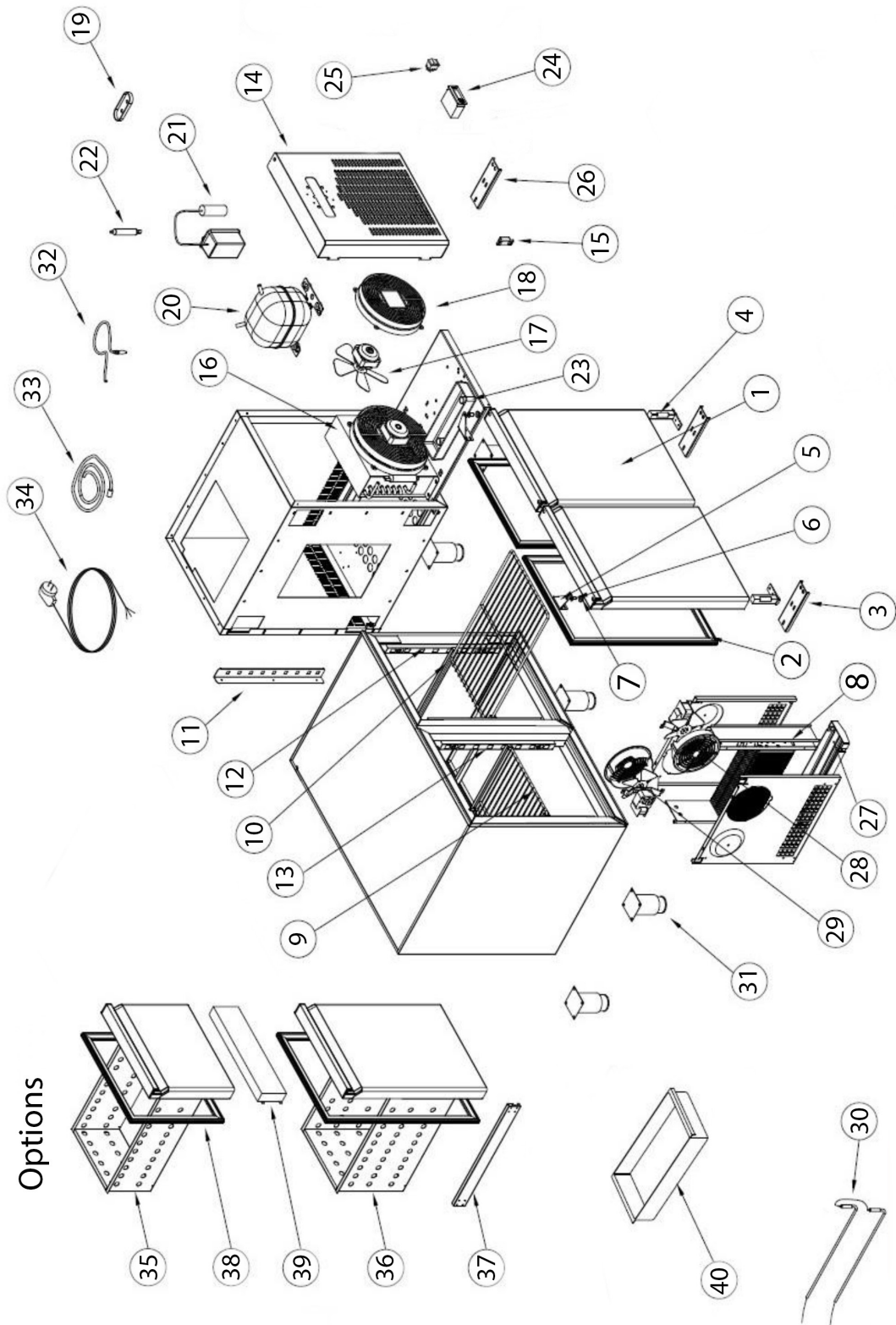

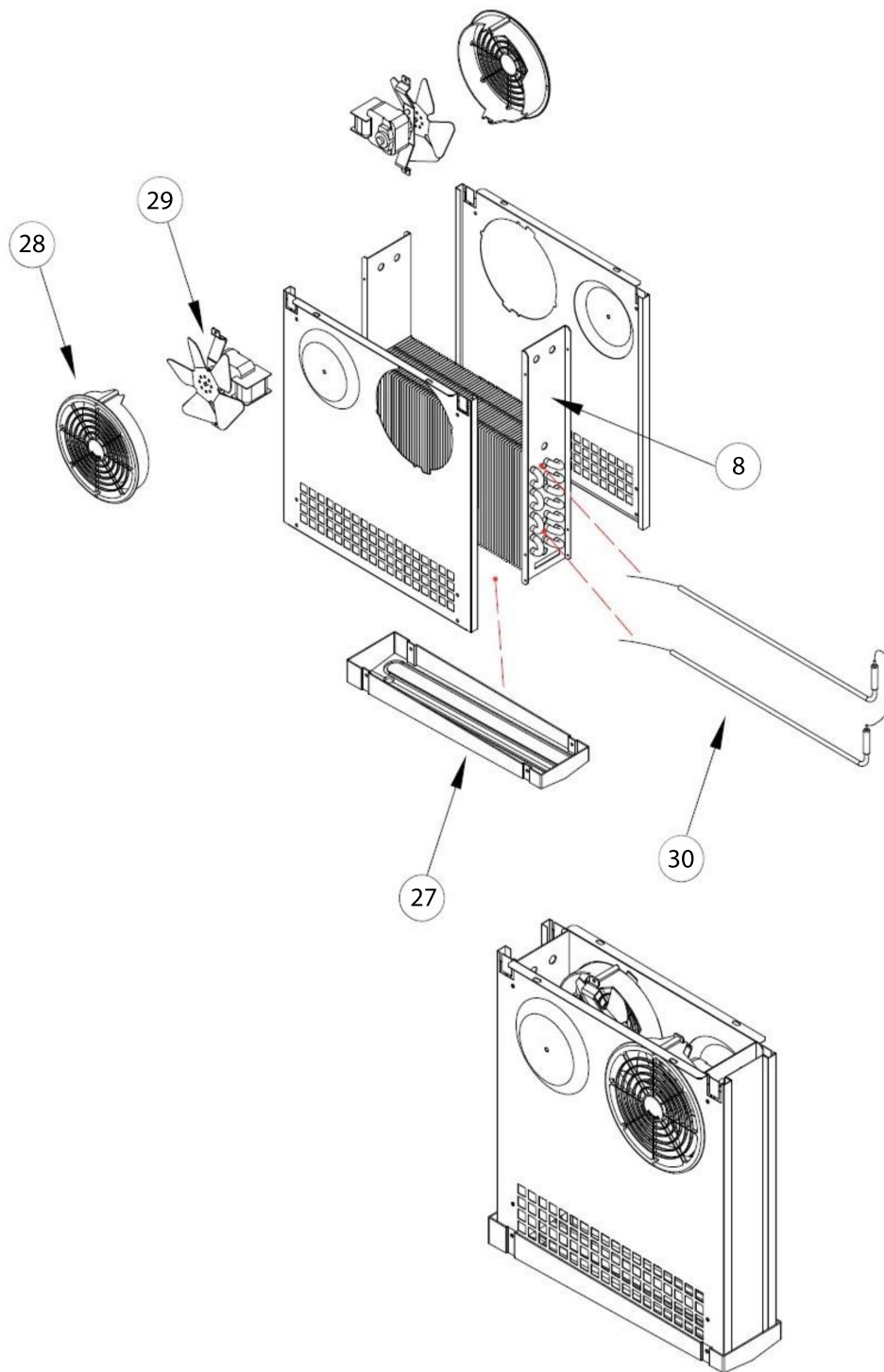

Undercounter - Evap Coil Group Detail

Parts List		
Number	QTY	Component
1	2	Door
2	2	Door Gasket
3	2	Lower Hinge Bracket
4	2	Upper Hinge and Parts
5	2	Upper Hinge
6	2	Upper Hinge Pim
7	2	Hinge Plastic
8	1	Evaporator
9	2	Shelf-CSN 430 X 325
10	4	Shelf Guide - CSN 455mm
11	2	Shelf Bracket Back
12	4	Shelf Bracket Side
13	2	Shelf Bracket Middle
14	1	Canopy
15	2	Magnet Hinges
16	1	1/4 HP Condensor
17	1	10W Fan Motor
18	1	Condensor Fan Plastic
19	1	Prop Cover
20	1	Compressor EMT 6160 Z 1/4HP
21	1	Role Box
22	1	Dryer
23	1	Water Box
24	1	Digital Thermostat Two Probe
25	1	Power switch
26	1	Canopy Hinge
27	1	Evaporator Cup
28	2	Plastic Fan Protection
29	2	Evaporator Fan Motor
30	1	200W Resistance
31	5	Stainless Steel Leg
32	1	Prop
33	1	Prop
34	1	Plug Cable
35		1/2 Drawer
36		1/2 Drawer
37		Drawer Rail
38		Drawer Gasket
39		Drawers Middle Bridge
40	1	Under Counter Ref Evaporator

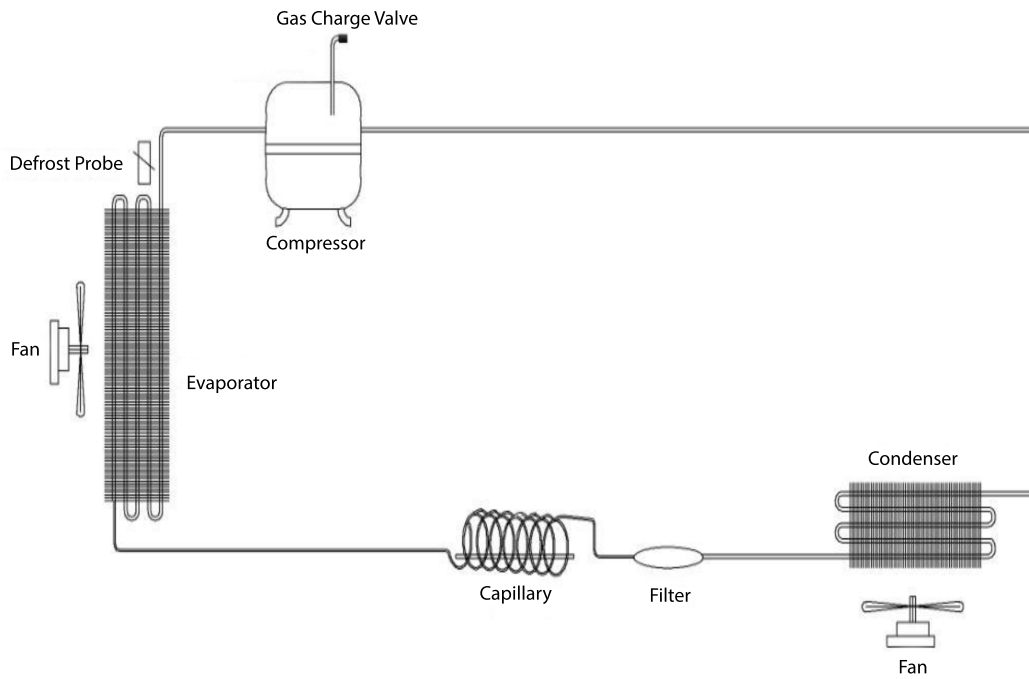

Horizontal Refrigerators Electrical Schematic

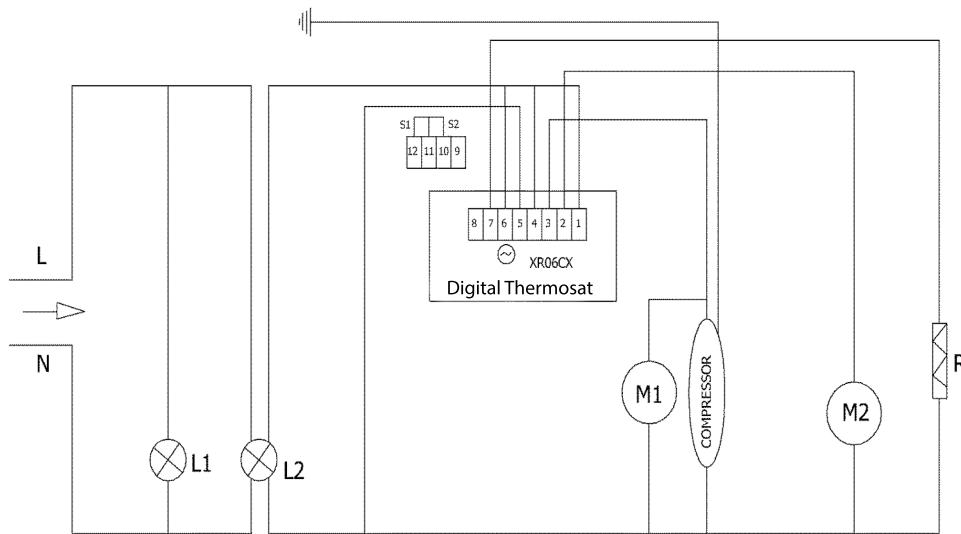

XR060CX : Digital Thermostat
 M1: Condenser Fan Motor
 M2 : Evap Fan Motor
 S1: Room Probe
 S2 : Evaporator Probe

L1 : Power Lamp
 L2 : On-Off Light
 R : Evaporator Resistance